



ISCAR's Solutions for the Railway Industry



Machining Intelligently
ISCAR HIGH Q LINES

Member IMC Group
iscar
www.iscar.com

Railway Industry

The railway industry has played an important role in the past two decades becoming one of the leading means of transportation for freight and passengers. Ongoing investments in modern railway track infrastructure has opened a new edge to high-speed transportation mobility.

In addition, the environmental advantages offered in railway transportation is expanding railway traffic awareness. To keep up with the growing demands in this heavy metalworking industry, ISCAR has developed special machining expertise for railway components with innovative cutting tools and robust carbide grades.

Environmental Value



Reduced Highway Congestion



Fuel Efficiency



Fewer Emissions

Transportation



Diesel Locomotive (~200 Km/Hr.)



High Speed Train (~380 Km/Hr.)



Electric Train



Heavy Cargo Freight Train



Underground Train



Inner City Light Rail

Railway Infrastructure



Typical Rail Profiles

For inner city, long range cargo and passenger infrastructures

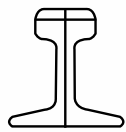

AS22

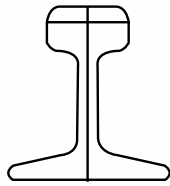

AS31

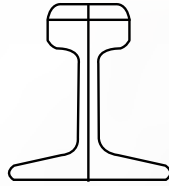

AS41

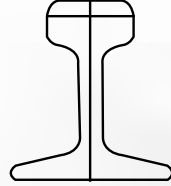

AS47

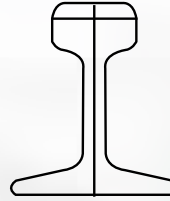

AS50

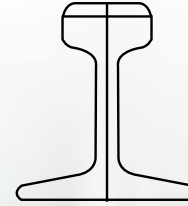

AS53

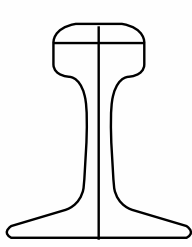

AS60

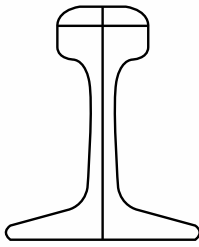

AS68

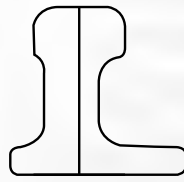

ZU - 160

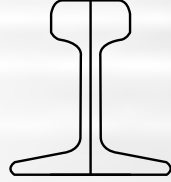

91LB

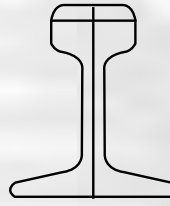

NZ50

For Switchers and Crossing Asymmetric Rails

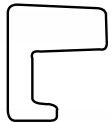

UIC33

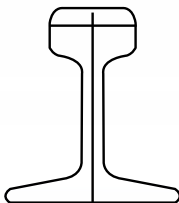

UIC54

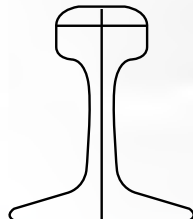

UIC60

Tram Rails

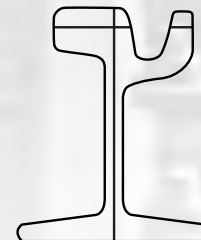

T62

Types of Railway Switchers and Separators



Crossover



Switch Diamond



Three-Way Switch

Switchers - Connecting Links UIC54

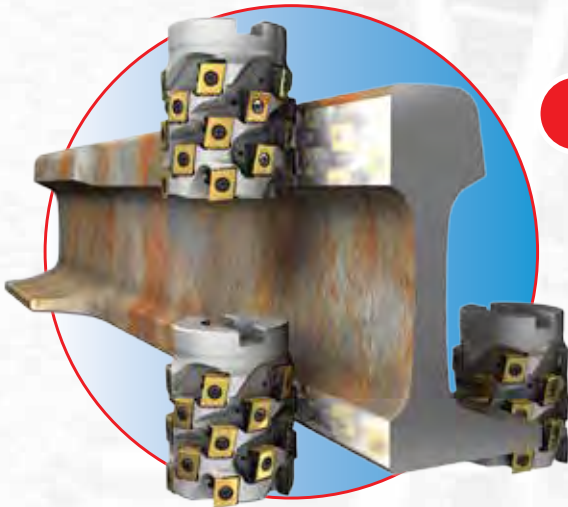

1

HELITANG T490 LINE

Shoulder Milling

Range: Ø20 - 125 mm

T490 extended flute cutters with rigidly clamped tangential four cutting edged inserts for machining side track profiles, switchers and separators.

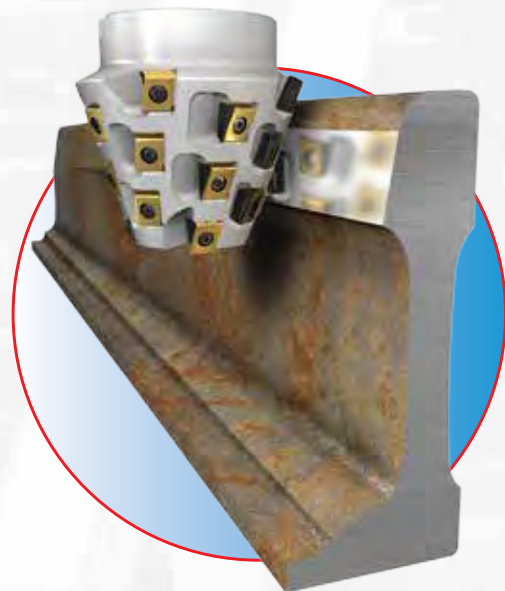
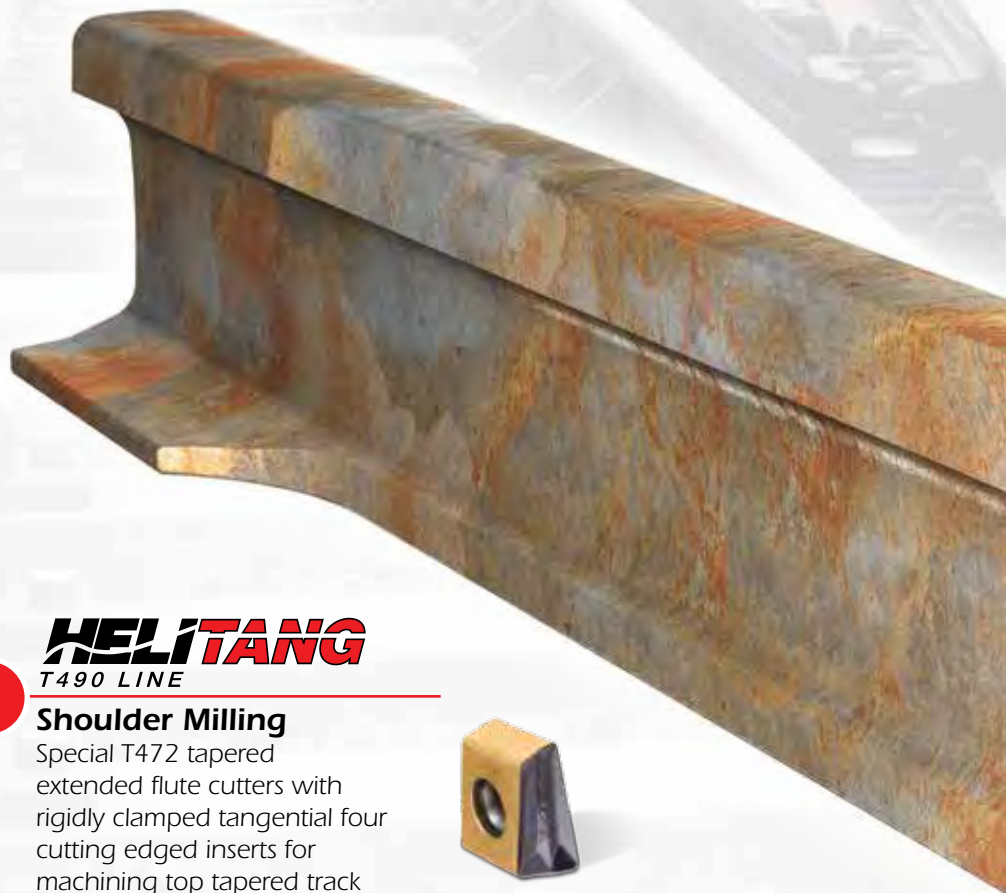

2

HELITANG T490 LINE

Shoulder Milling

Special T472 tapered extended flute cutters with rigidly clamped tangential four cutting edged inserts for machining top tapered track profiles, switchers and separators. ISCAR offers a standard line of cutters with different approach angles ranging from 22° up to 75°.





TANGMILL

TANGENTIAL LINE

Shoulder Milling

Special concave profile extended flute cutters with rigidly clamped tangential inserts for machining top radius profiles, switchers and separators.



**SPECIALLY
TAILORED**

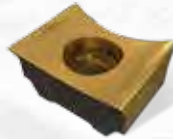

3

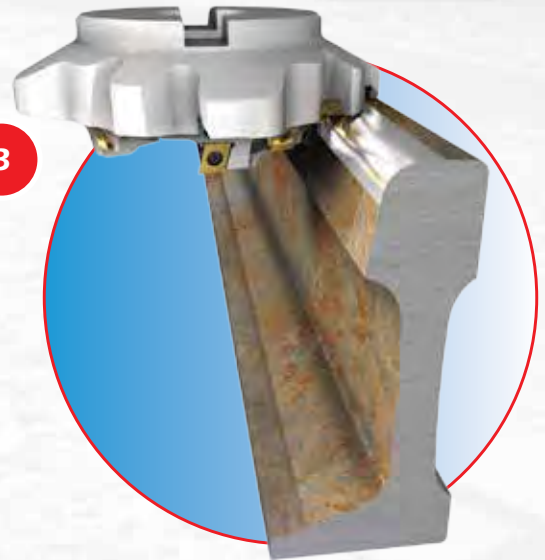

TANGMILL

TANGENTIAL LINE

Shoulder Milling

Special concave profile extended flute cutters with rigidly clamped tangential inserts for machining top radius profiles, switchers and separators.



**SPECIALLY
TAILORED**



4

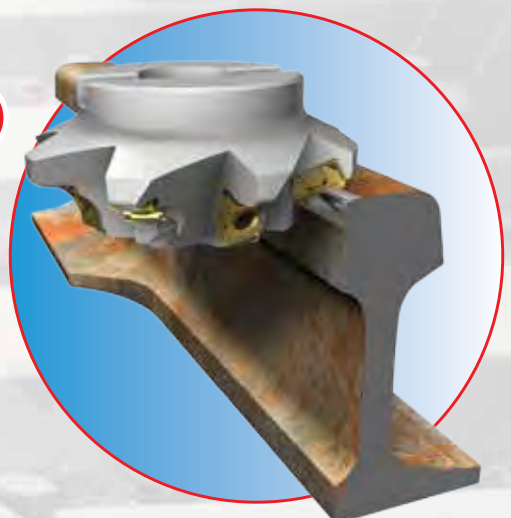

Switchers - Connecting Links

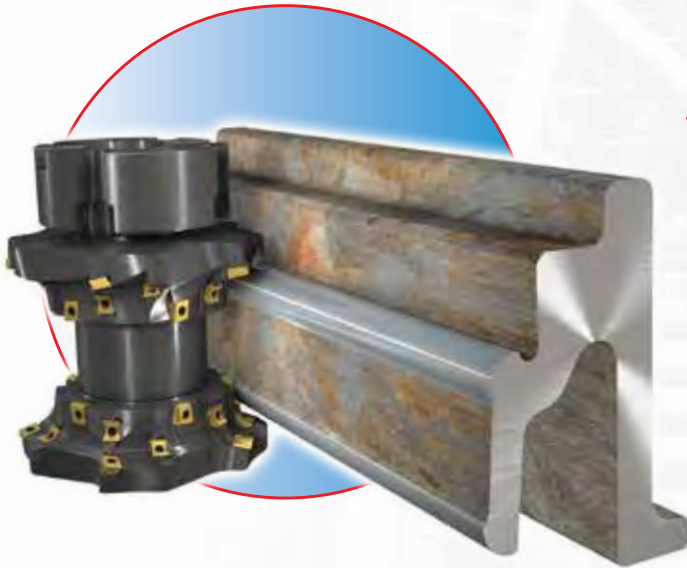

HELITANG T490 LINE

Shoulder Milling

Special concave profile extended flute cutters with tangential inserts for switcher profiling.

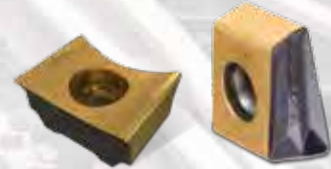

**SPECIALLY
TAILORED**

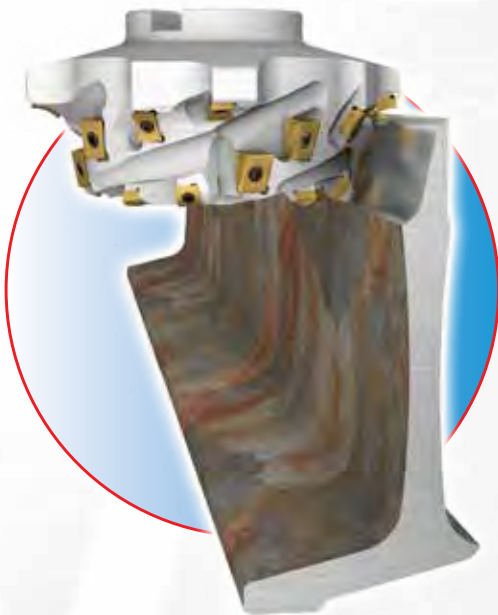

HELITANG T490 LINE

Shoulder Milling

Special T478 extended flute cutters with rigidly clamped tangential positive inserts for smooth cut machining of switchers and separators.

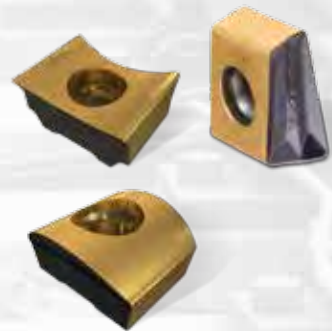

**SPECIALLY
TAILORED**



**SPECIALLY
TAILORED**

TANGMILL TANGENTIAL LINE

Rough Milling

Special face mount web slotting cutters for machining steel crossings and transition rails made of alloy manganese. The cutter's positive rake cutting action dramatically reduces forces and improves tool consistency in difficult-to-clamp rail shapes while providing a smooth cut and eliminating hard finishing applications.



Switchers - Connecting Links

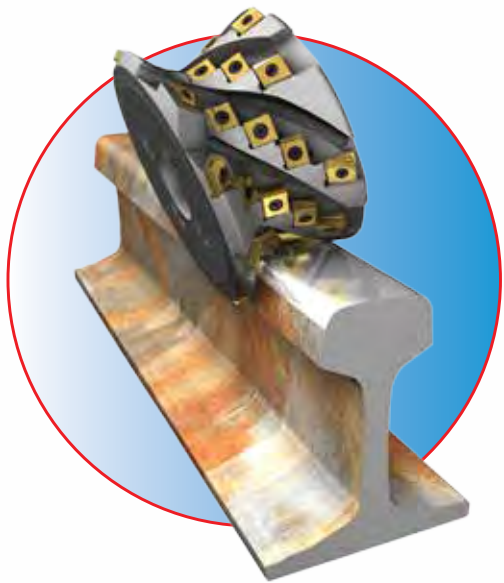

TANGMILL

Tangential Cutters

Special concave profile extended flute cutters with rigidly clamped tangential inserts positioned on an angular spindle axis for smooth machining of switchers and separators.



TANGMILL

Switcher/Separator Milling

Special spherical extended flute cutters with rigidly clamped tangential inserts for machining switcher and separator shoulders. Their unique design, with a combination of left and right flutes, assures minimum vibrations and smooth cutting.

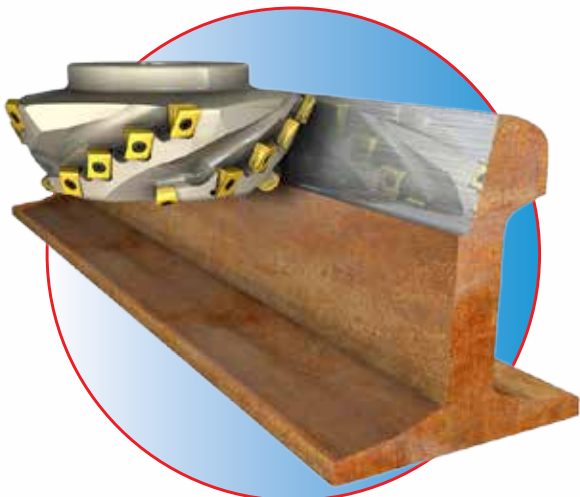

HELITANG

T490 LINE

Tapered Switcher Blade Machining

Specially tapered extended flute cutters with helical flutes for high metal chip removal and rigidly clamped tangential inserts for machining top tapered track profiles, switchers and separators.

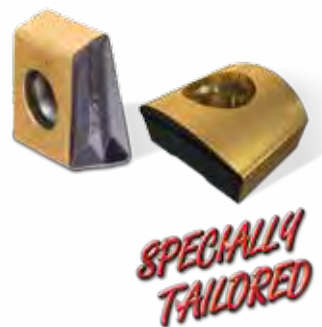

Connecting Links UIC33



DR-TWIST INDEXABLE DRILL LINE

Drilling

Range: Ø12 - 80 mm

Drills with spiral coolant channels and a strong cutter body with excellent resistance to torsion and very efficient chip evacuation.

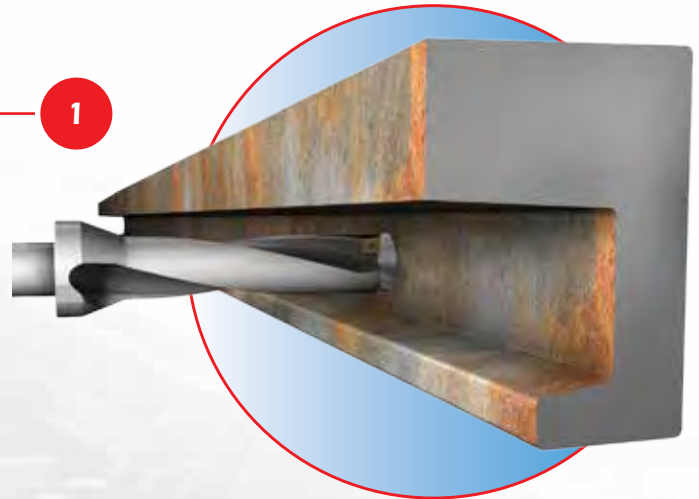

HELITANG T490 LINE

Shoulder Milling

Range: Ø20 - 125 mm

T490 extended flute cutters with rigidly clamped tangential inserts for machining switchers and separators.

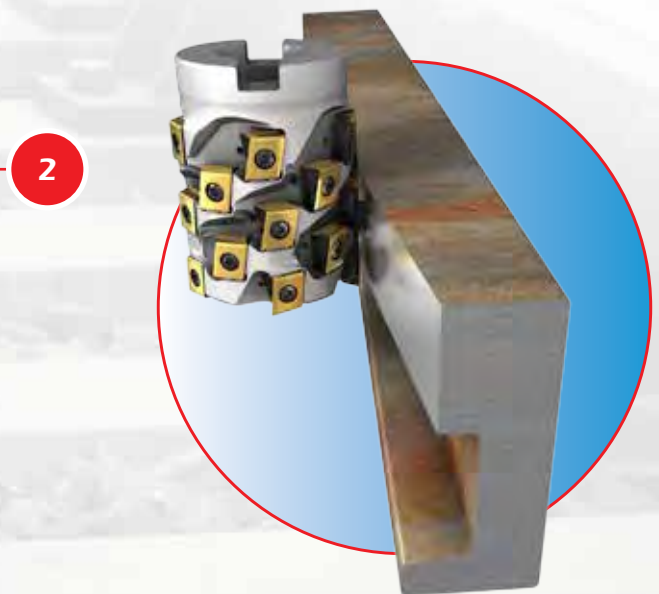

The UIC33 rail is a common part which is produced to keep the wheel in correct alignment when approaching a switch.



Connecting Links

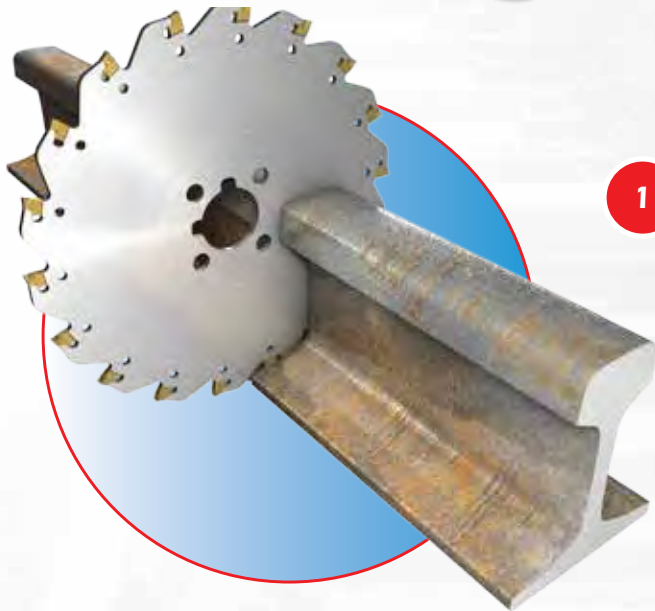

1

TANG-GRIP PARTING LINE

Slitting

Range: Ø100 - 160 mm

Indexable slotting cutters with tangentially mounted inserts and a unique clamping design for durable parting.

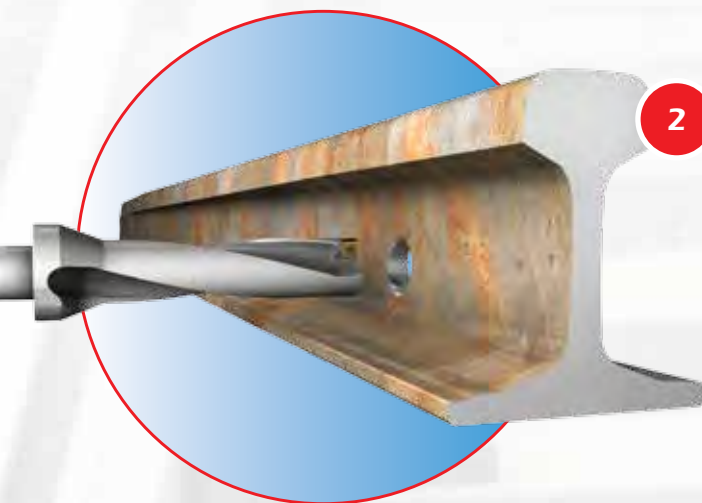

2

DR-TWIST INDEXABLE DRILL LINE

Drilling

Range: Ø12 - 80 mm

Drills with spiral coolant channels and a strong cutter body with excellent resistance to torsion and very efficient chip evacuation.

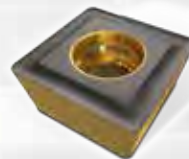



**SPECIALLY
TAILORED**

HELITANG T490 LINE

Shoulder Milling

Special profile extended flute cutters with rigidly clamped tangential inserts for machining switchers and separators.



**SPECIALLY
TAILORED**

HELITANG T490 LINE

Shoulder Milling

Special profile extended flute cutters with rigidly clamped tangential inserts for machining switchers and separators.



Switchers



1

HELITANG T490 LINE

Shoulder Milling

Special T490 extended milling cutters with rigidly clamped tangential four cutting edged inserts for machining switchers and separator shoulders.



SPECIALLY TAILORED



2

HELITANG T490 LINE

Shoulder Milling

Special or concave profile extended flute cutters with tangentially clamped inserts for machining top and bottom filter track profiles, switchers and separators.



SPECIALLY TAILORED



3

1

2

4



HELITANG

T490 LINE

Shoulder Milling

Special T479 tapered extended flute cutters with tangentially clamped inserts for machining switchers and separators and semi-finishing operations.

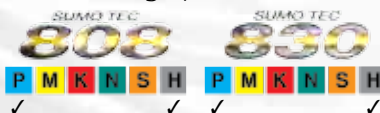

HELITANG

T490 LINE

Shoulder Milling

Special T414 tapered cutters with tangentially clamped inserts for machining top and bottom track profiles, switchers and separators.

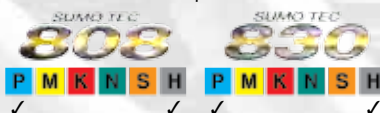

Switchers

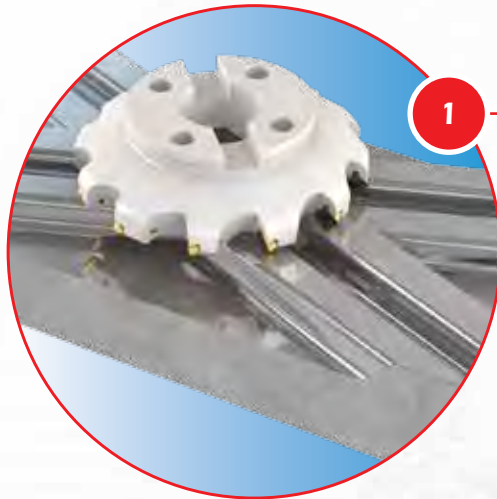

HELIDO 800 LINE

Face Milling

Range: Ø50 - 315 mm

45° face milling cutters carrying square or octagonal double-sided inserts with 8 and 16 cutting edges for roughing operations at an 8 mm depth of cut.

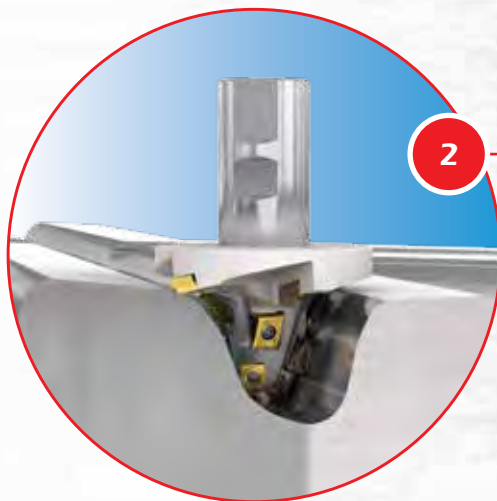
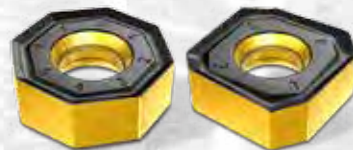
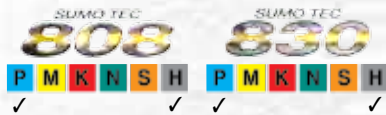

HELITANG T490 LINE

Deep Shouldering (Contour)

Special T479 full profile cutters for machining switchers and semi-finishing operations.

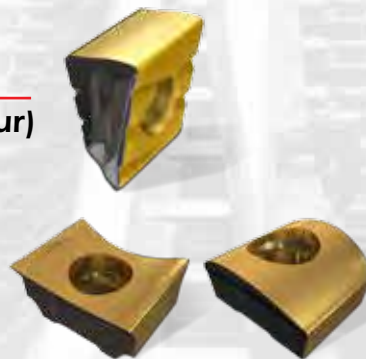
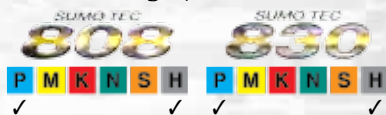

**SPECIALLY
TAILORED**

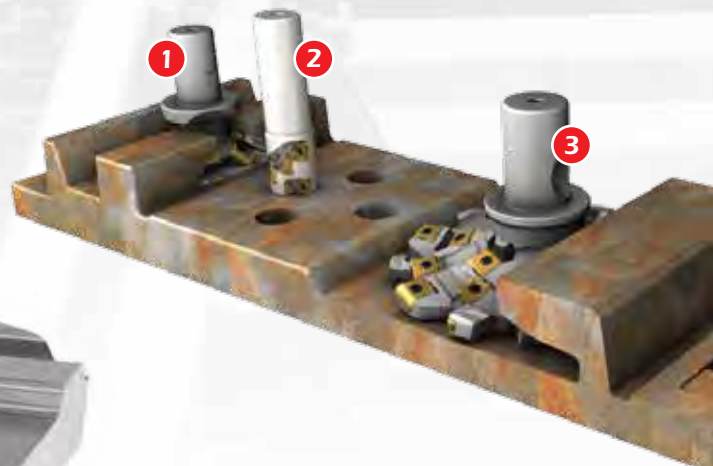
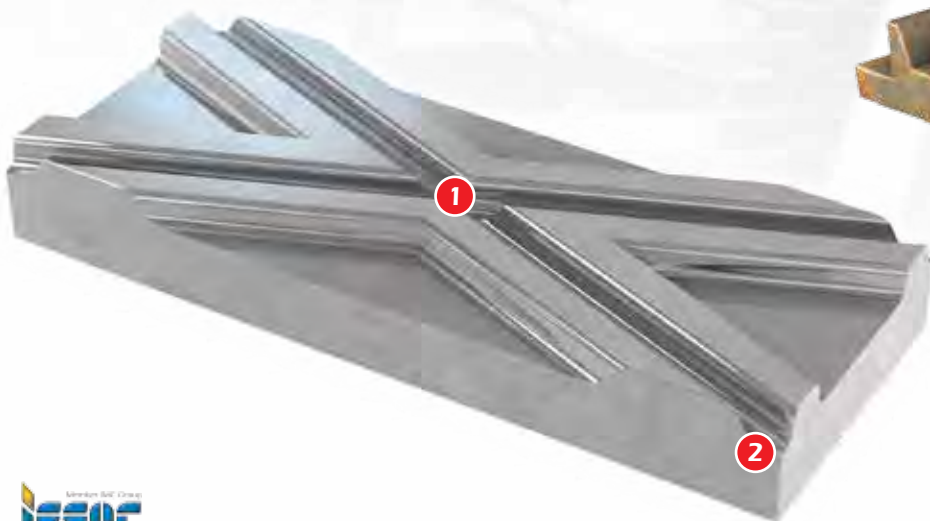

Slide Plate



HELIDO

490 LINE

Slot Milling

Range: Ø25 - 100 mm

H490 is an extended flute cutter characterized by radially clamped double-sided rectangular inserts with 4 helical cutting edges available in 09 / 12 / 17 mm sizes.

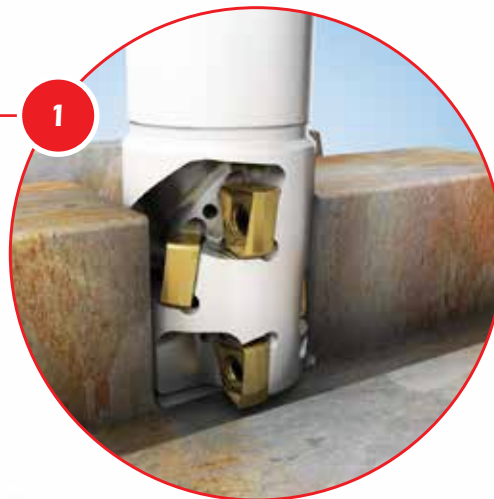

TANGMILL

TANGENTIAL LINE

Profile Slot Milling

Special tangential slot milling cutters for machining profile slots and grooves on rail track connecting links.



**SPECIALLY
TAILORED**

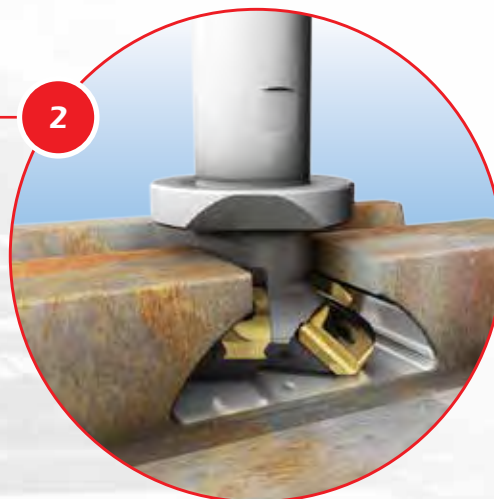

TANGMILL

TANGENTIAL LINE

Profile Slot Milling

Special tangential slot milling cutters for machining profile slots and grooves on side plates and connecting links.

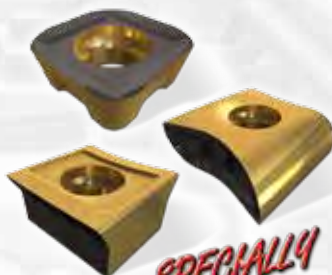

**SPECIALLY
TAILORED**

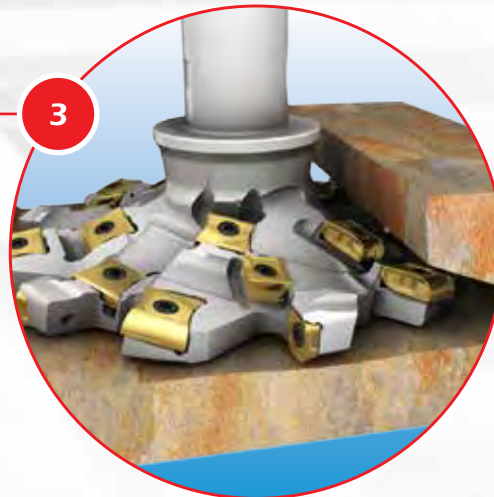
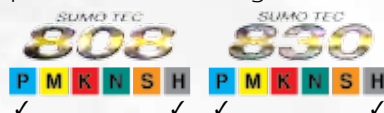

New Wheel Production



ISOTURN

Round inserts and special CAMFIX holders with a screw and top lever for robust clamping.



ISOTURN

Special CAMFIX holders with a screw and top lever for roughing and finishing boring operations.





1
Roughing
Application

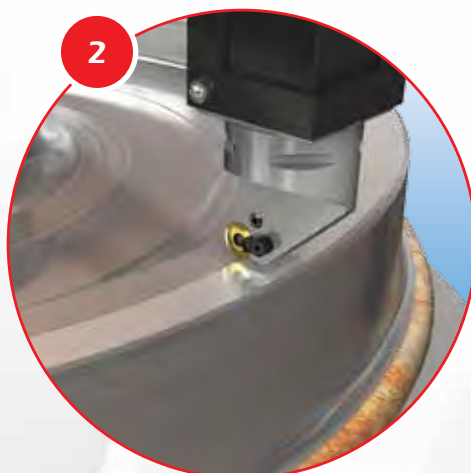

2
Finishing
Application



3
Finishing
Application



4
Rough Rim
Turning

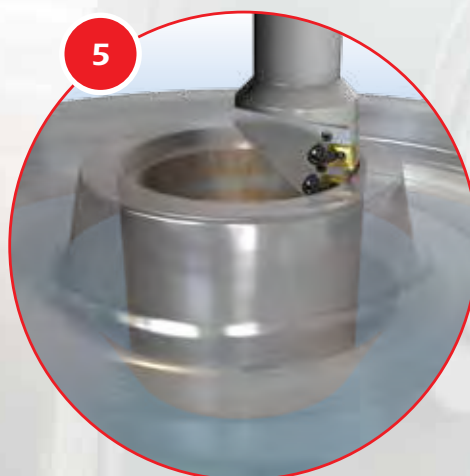

5
Roughing and Finishing
Combi-Bore

New Wheels Turning

Round Inserts

For Roughing and Finishing Operations and Machining Rim and Web Areas



RCMT 20-14 (MO)
Screw Clamped Insert



RCMT 25-SR (MO)
Screw Clamped Insert

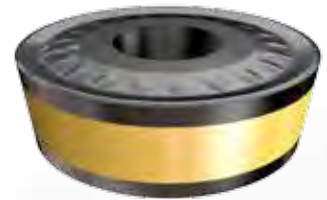

RCMX 25-NR (00)
Lever Clamped Insert



RCMX 32-NR (MO)
Screw Clamped Insert



RCMX 32-NR (00)
Lever Clamped Insert



SPECIALLY TAILORED
RCMX 32-WKR (00)
Lever Clamped Insert



SPECIALLY TAILORED
RCMX 32-SE50 (00)
Lever Clamped Insert



RCMX... (00) - Lever Clamping
RCMX... (MO) - Screw Clamping (Special Holder)
RCMT... (MO) - Screw Clamping



Cutting Data

Speed ↑ High ↓ Low	P	Grade Recommendation
	IC5005	A TiC/Al ₂ O ₃ multilayer, CVD coated grade. Used for grooving and turning gray and nodular cast iron at medium to high cutting speeds.
	IC8150	A very hard substrate with a cobalt enriched layer, improved MTCVD TiCN and a thick alpha Al ₂ O ₃ CVD coating. Features excellent thermal stability, resistance to chipping and plastic deformation. Recommended for high speed machining of steel at stable or slightly unstable conditions.
	TP20	A hard substrate with a cobalt enriched layer, MTCVD TiCN and alpha Al ₂ O ₃ CVD coating. Excellent thermal stability and resistance to chipping and plastic deformation. Recommended for high speed machining of steel at stable conditions.
	IC8250	A tough substrate with a cobalt enriched layer combined with improved MTCVD TiCN and a thick alpha Al ₂ O ₃ CVD coating. Recommended for general use machining of steel in a wide range of conditions, featuring high toughness and resistance to chipping and plastic deformation.

Cutting data by area:

Area	Vc	f
A	70 - 200 m/min	0.5 - 2.0 mm/rev
B	50 - 100 m/min	0.5 - 1.5 mm/rev

Depth of cut according to chipbreaker geometry:

14	0.3 - 3.5 mm
SR/NR	1.5 - 7.0 mm
SE50/WKR	3.0 - 12 mm

In case of worn wheels with skid flats, built-up and shelled tread or thermal cracks, reduce the cutting speed to ISCAR's recommended minimum speed. High carbon wheels should be machined at ISCAR's recommended low range cutting speed. Feeds should be optimized within the recommended range per chipformer and actual chip formation.

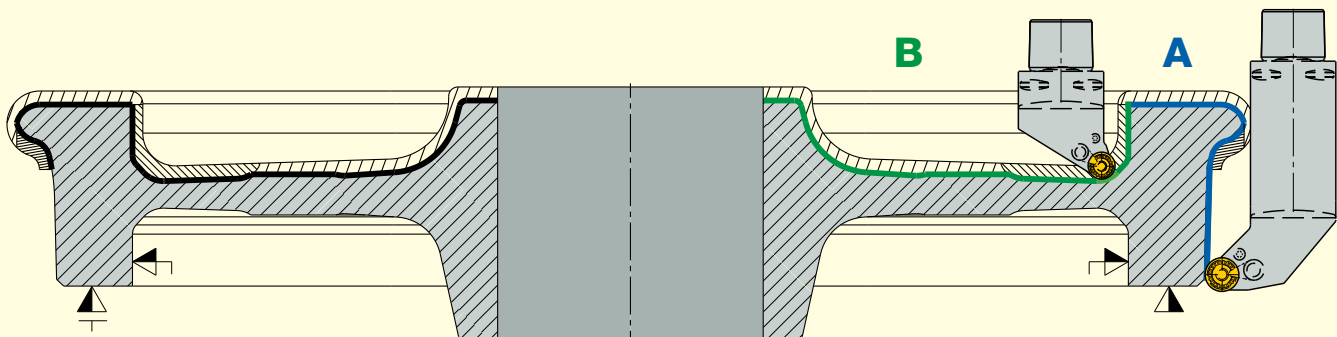
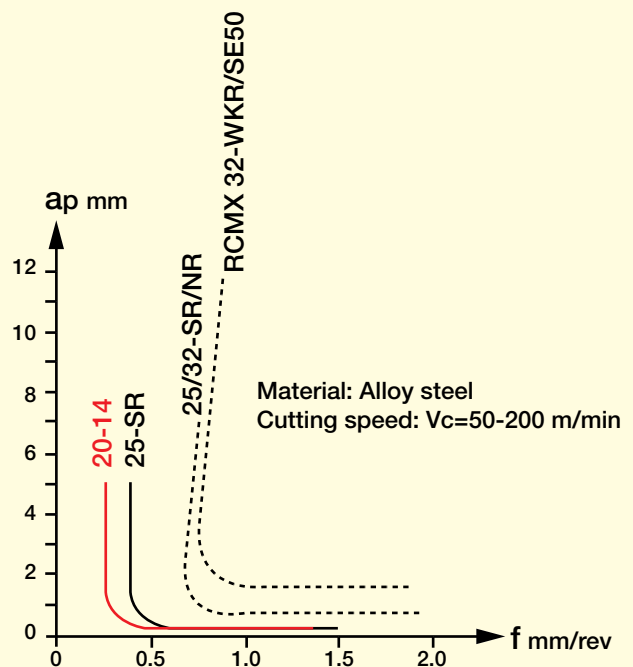

Re-Turning Rail Wheel

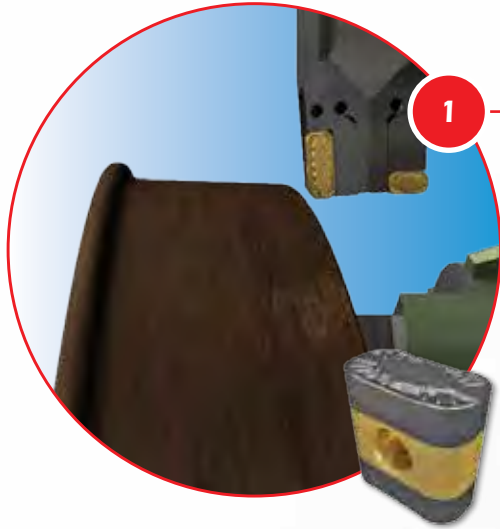

ISOTURN

Rough Turning

Tools with two cartridges and tangentially mounted inserts for re-turning railroad wheels are able to machine the entire outer wheel profile in a single cut.



ISOTURN

Rough Turning

Longitudinal turning is performed with a 30 mm long and 4 mm corner radius tangentially clamped insert, positioned with its long side against the machining direction. This insert can handle large cutting depths for roughing or semi-finishing applications, depending on the outer wheel condition.



ISOTURN

Rough Turning

Machining depth can range from 0.3 mm to 12 mm depending on the outer wheel condition prior to re-conditioning. Large depths of cut are usually performed by several machining paths in order to prevent heavy loads and poor insert life.

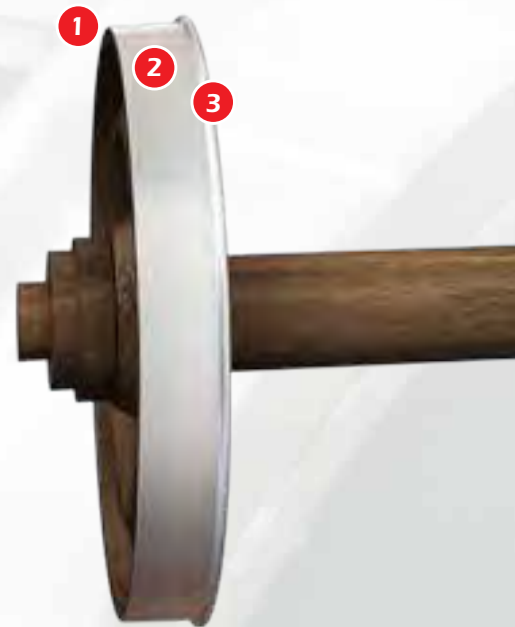



ISOTURN

Rough Turning

A 19 mm long and 4 mm radius tangentially clamped insert positioned perpendicularly to the larger insert is used to machine the massively eroded rim zone.

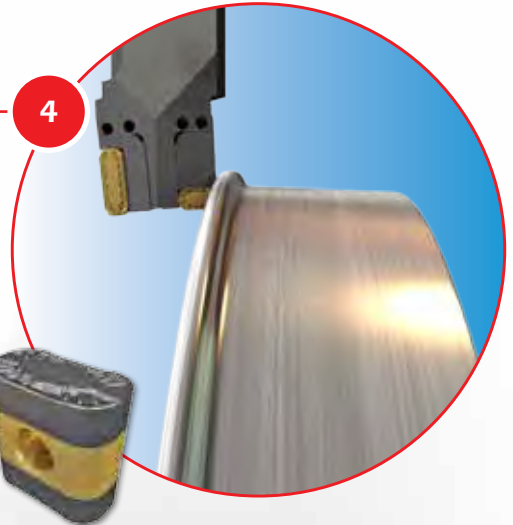

Railroad car wheel re-turning can be found in every country where trains are used for passenger or freight transportation. It is most common for wheels to be re-turned on a dedicated portal wheel, universal lathe or under floor lathes.

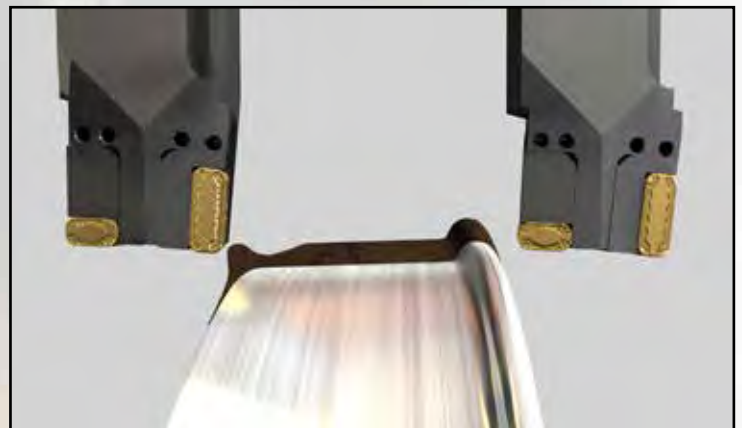
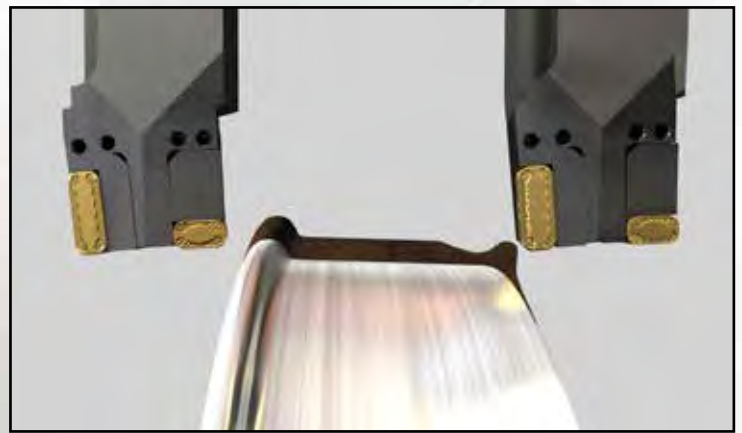

Re-Turning Rail Wheel



Conventional Wheel Lathe



CNC Portal Wheel Lathe



Inserts and Tools



Toolholders and Cartridges for Under Floor Re-turning Lathes (Model 106 Thread Profile Machine)

Assembly and Spare Parts

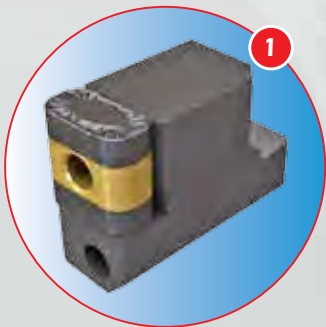

PRWR/L 177-CA-19



PRWR/L 175-CA-19



PRWR/L 175-CA-30



Designation	Screw	Lever	Key
LNMX 191940	SR LCS 5	LR 5	HW
LNMX 301940			3.0



Chipformers and Grades



LNMX 191940-WF
For finishing operations



LNMX 191940-WM
For medium/
semi-finishing operations



LNMX 301940-WM
For medium/
semi-finishing operations



LNMX 301940-WR
For roughing operations



LNMX 301940-WKR
For roughing operations



LNMX 301940-WMR
For roughing operations

Chip Formation at the Rim Curve

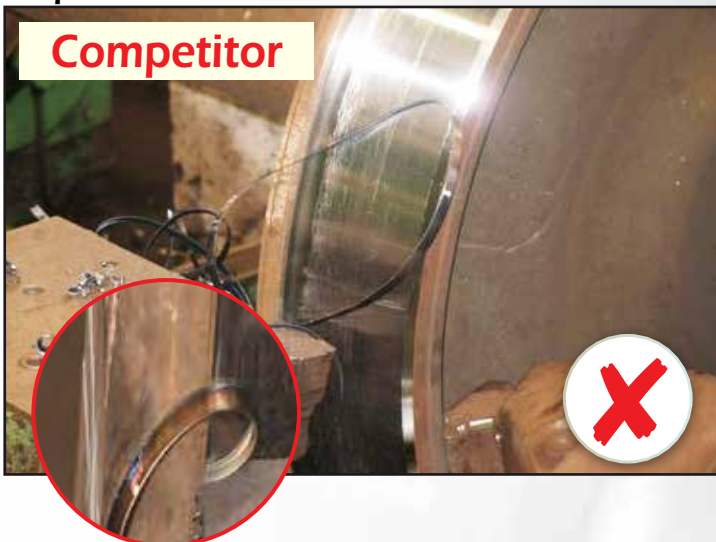

One of the common problems in wheel re-turning is chip formation during the back turning operation at the rim zone.



The WM chipformer (on the 30 mm insert) has been specifically designed to prevent long chip formation during rim turning.



Cutting Data

Speed ↑ High ↓ Low	P	Grade Recommendation
	IC5005	A TiC/Al ₂ O ₃ multilayer, CVD coated grade. Used for grooving and turning gray and nodular cast iron at medium to high cutting speeds.
	IC8150	A very hard substrate with a cobalt enriched layer, improved MTCVD TiCN and a thick alpha Al ₂ O ₃ CVD coating. Features excellent thermal stability, resistance to chipping and plastic deformation. Recommended for high speed machining of steel at stable or slightly unstable conditions.
	IC9150	A hard substrate with a cobalt enriched layer, MTCVD TiCN and alpha Al ₂ O ₃ CVD coating. Excellent thermal stability and resistance to chipping and plastic deformation. Recommended for high speed machining of steel at stable conditions.
	IC8250	A tough substrate with a cobalt enriched layer combined with improved MTCVD TiCN and a thick alpha Al ₂ O ₃ CVD coating. Recommended for general use machining of steel in a wide range of conditions, featuring high toughness and resistance to chipping and plastic deformation.
	IC9250	A tough substrate with a cobalt enriched layer combined with MTCVD TiCN and a thick alpha Al ₂ O ₃ CVD coating. Recommended for general use machining of steel in a wide range of conditions, featuring high toughness and wear resistance.

Cutting Data Recommendations



Cutting Data by Area:

Area	Vc	f
A	30 - 70 m/min	0.3 - 1.8 mm/rev
B	50 - 100 m/min	0.5 - 2.0 mm/rev
C	50 - 100 m/min	0.5 - 2.0 mm/rev

Depth of cut according to chipbreaker geometry:

WF	0.3 - 3.5 mm
WM/WMR	1.5 - 7.0 mm
WR/WKR	3.0 - 12 mm

In case of worn wheels with skid flats, built-up and shelled tread or thermal cracks, reduce the cutting speed to ISCAR's recommended minimum speed.

High carbon wheels should be machined at ISCAR's recommended low range cutting speed. Feeds should be optimized within the recommended range per chipformer and actual chip formation.

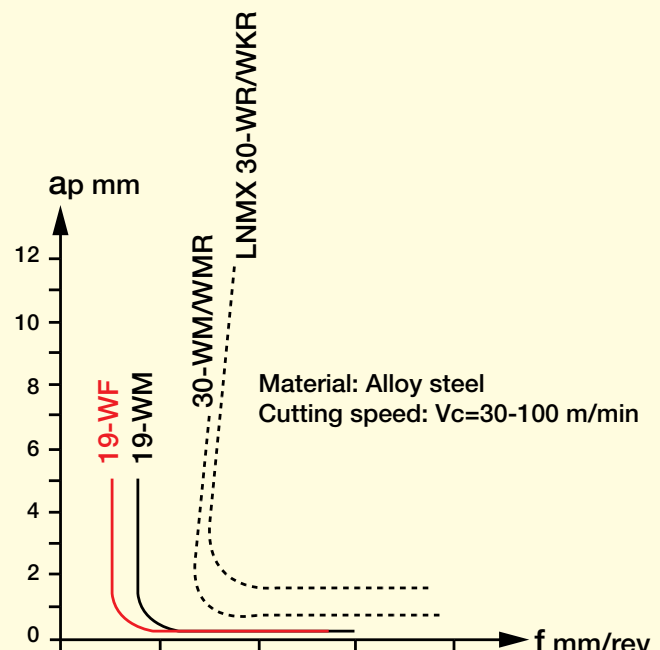

Under Floor Wheel Milling

Locomotive Re-Profiling Wheels



Under floor, counter-wheel machining is intended for re-profiling locomotive wheels without the need to remove the wheels.



Capable of simultaneously re-profiling both left and right wheels and provide high profile accuracy, preserving the dimensions of the wheels under various conditions.



ROUNDMILL

Special-type extended flute cutters carrying accurate round inserts for re-profiling locomotive wheels. Recommended for under floor machining.

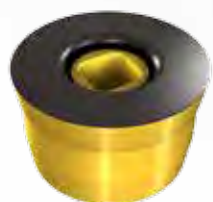

**SPECIALLY
TAILORED**

RPMW 1609-PP-TM

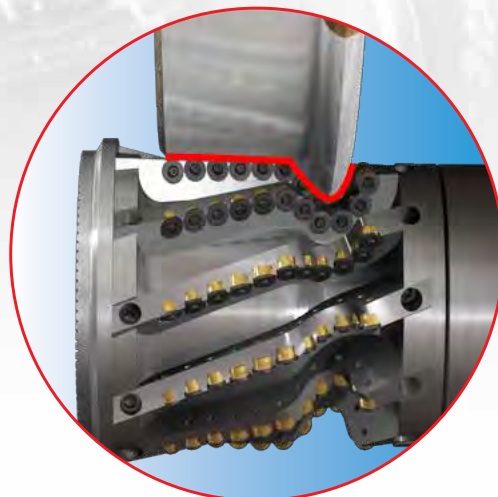

Turning Rail Car Wheel Axles

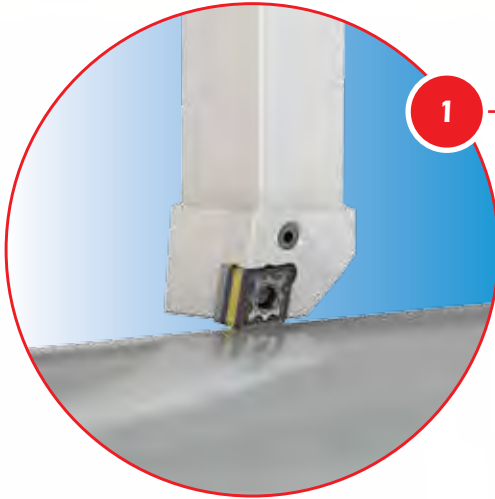

1

DOVE IQ TURN HEAVY DUTY LINE

External Turning (Roughing)

A line of external and internal tools and large-sized inserts for heavy duty applications.



COMG 160612 R3P-IQ



2

ISOTURN

External Turning (Semi-Finishing)

Double-sided trigon wiper inserts for high surface finishing at high feed rates.

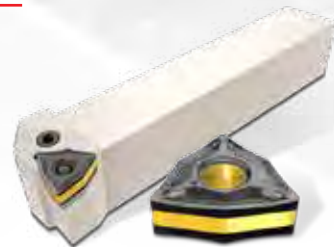

WNMG 080408-WG

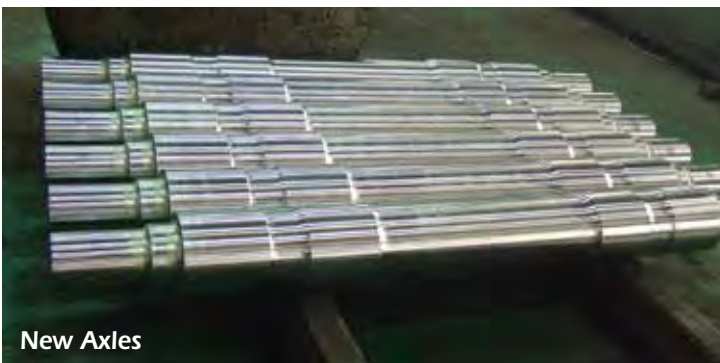

New Axles



Reconditioned Axles



GIF 8.00E-4.00

CUTGRIP

External Grooving

ISCAR groove-turn tools (GRIP) offer a surface quality far superior when turning with standard ISO tools as compared to grinding operations.

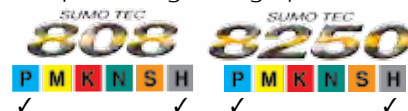

3



DCMT 13T504-F3P-SL

ISOTURN

Semi-Finishing

55° positive flank inserts for machining low carbon steel; recommended for semi-finish and finishing operations.



4



SUMOCHAM

CHAMDRILL LINE

Drilling

Range: Ø6 - 32.9 mm

The **SUMOCHAM** drill family is the most productive and profitable solution in the hole making industry.

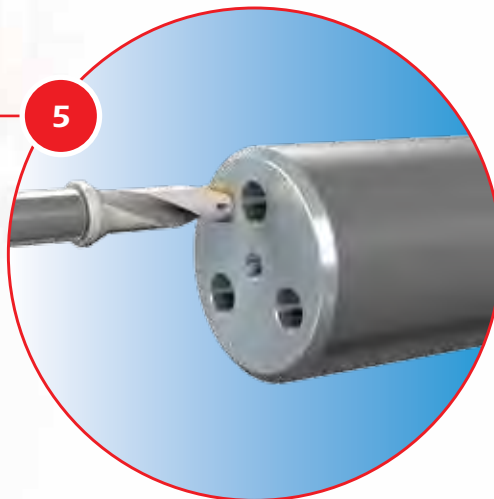

5

Machining Bogie Frames, Side A+B



HELIDO 800 LINE

Face Milling

Range: Ø50 - 315 mm.

Cutter: SOF45 D...-R18

Insert: S845 SNMU 1806ANR-MM

Insert: ONMU 070610-TR-MM

Helido 45° face milling cutters carry square or octagonal double-sided inserts with 8 and 16 cutting edges; recommended for roughing operations at an 8 mm depth of cut up.



HELIDO 890 LINE

Shoulder Milling

Range: Ø50 - 160 mm.

Cutter: S890 FSN D...-R13

Insert: S890 SNMU 1305 PNTR

Helido S890 face mills with square double-sided inserts; recommended for general milling applications at a 9 mm depth of cut.



SUMOCHAM CHAMDRILL LINE

Drilling

Range: Ø6 - 32.9 mm

The **SUMOCHAM** drill family is the most productive and profitable solution in the hole making industry

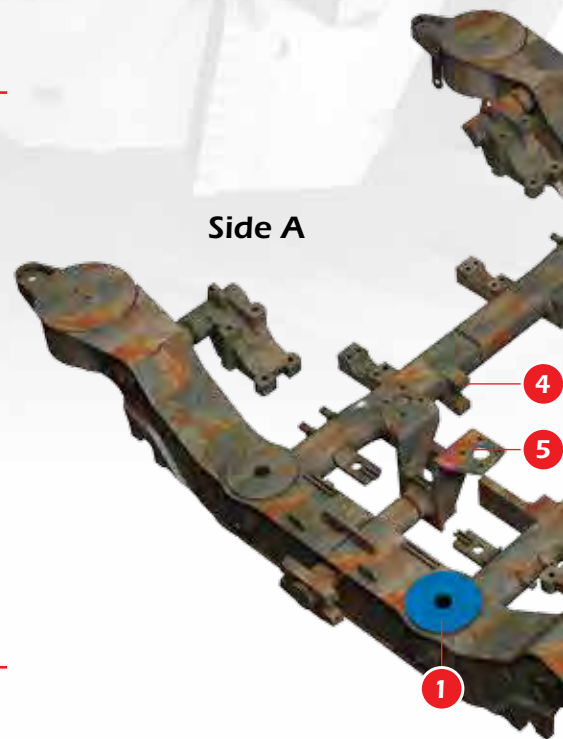

Side A

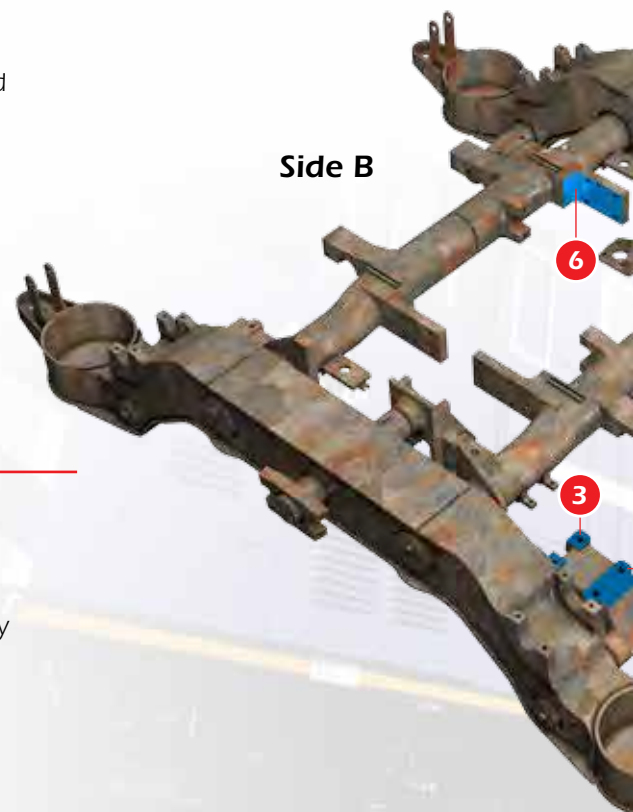

Side B



HELITANG T490 LINE

Shoulder Milling
Range: Ø25 - 250 mm.
Cutter: T490 ELN/FLN D...-13
Insert: T490 LNMT 1306 PNTR
The HELITANG T490 Line is recommended for shouldering and slotting operations at a 12 mm depth of cut.



DR-TWIST INDEXABLE DRILL LINE

Drilling
Range: Ø12 - 80 mm
Drills designed with spiral coolant channels and a strong cutter body with excellent resistance to torsion and very efficient chip evacuation.



MILLSHRED P290 LINE

Rough Shoulder Milling
Range: Ø25 - 100 mm
P290 is a family of extended flute cutters carrying inserts with 2 serrated cutting edges for rough and finishing operations and high overhang machining. The HL straight edged inserts are recommended for finishing operations.

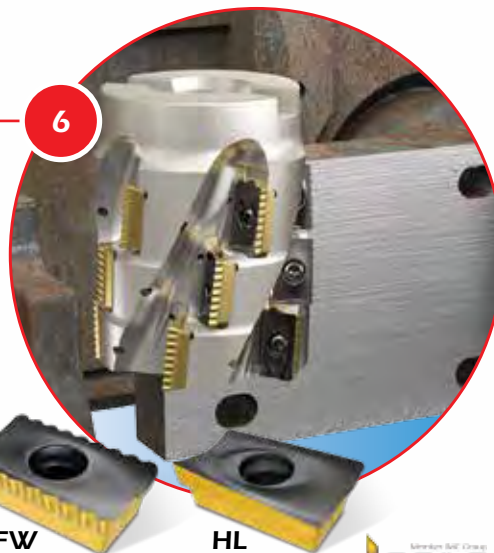
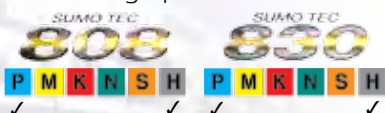

2

4

5

6

FW

HL

Locomotive Power Train Engine

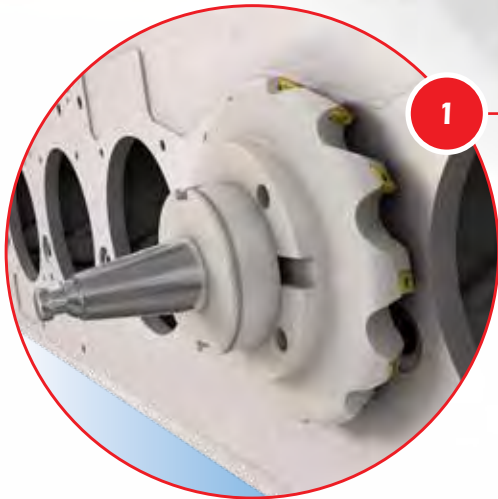

HELITANG T465 LINE

Rough Shoulder Milling

Range: Ø125 - 315 mm

65° face milling cutters carrying tangentially clamped inserts with four 22 mm long cutting edges.



TANGSLOT

Slot Milling

Range: Ø80 - 250 mm

Tangential slot milling cutters with cartridges carrying LNET12... tangential inserts with 4 cutting edges.

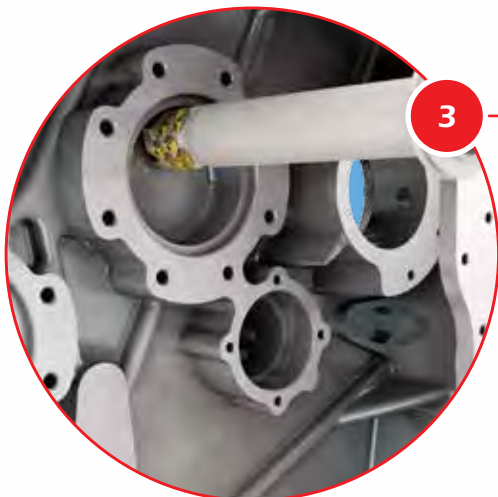
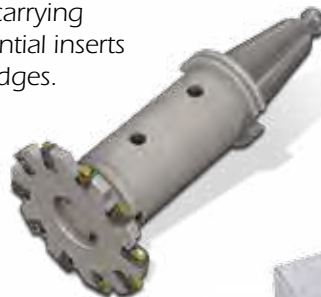

HELITANG T490 LINE

Deep Shoulder Milling

Range: Ø20 - 125 mm

Extended flute cutters carrying T490 LNHT/MT 08/13... tangential inserts with 4 cutting edges for higher productivity.



1



SOLIDDRILL

Deep Drilling

Range: Ø5 - 10xD

Solid carbide drills with coolant holes and a drilling depth of 20xD.

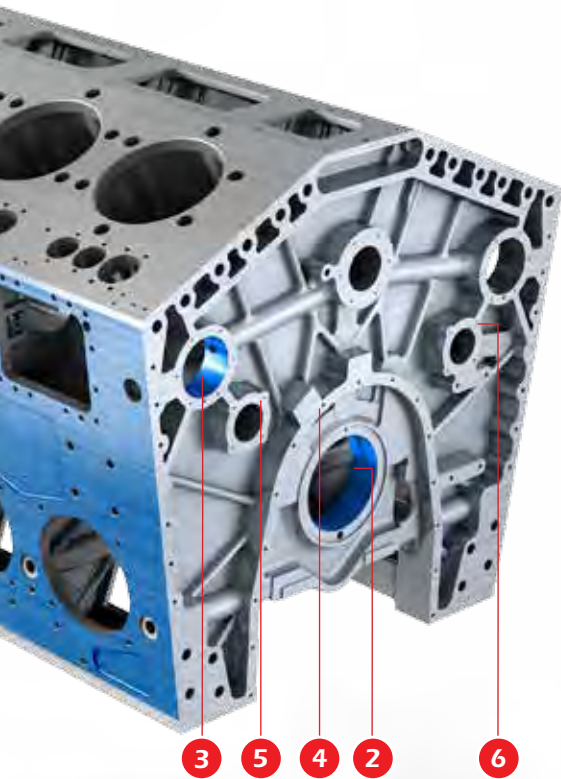
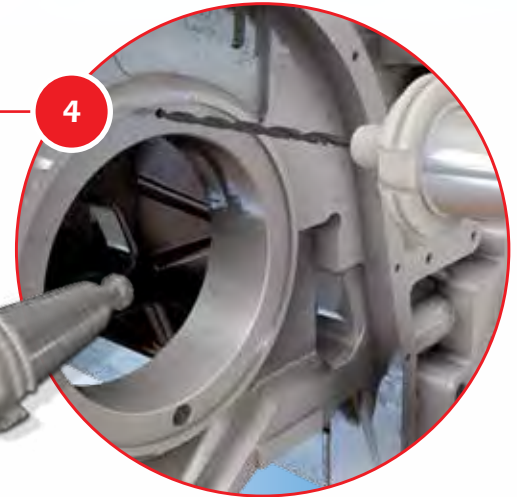

SOLIDTHREAD

Thread Milling

Range: Ø4 - 20 mm

Solid carbide 3 flute threading endmills with a short 3-tooth cutting zone and a released neck for the production of small internal threads.

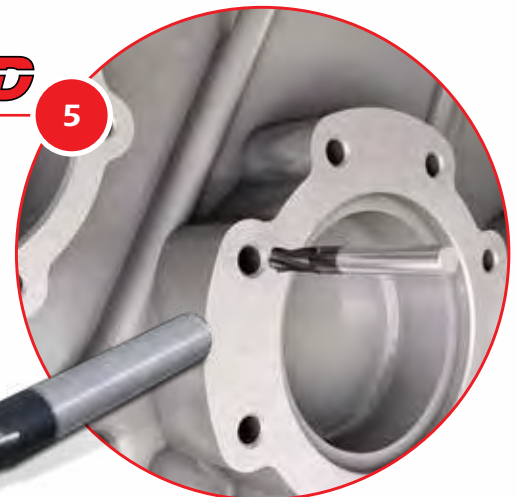

908
P M K N S H
✓ ✓

SUMOCHAM

CHAMDRILL LINE

Drilling and Chamfering

Special request indexable head drills with coolant holes.



908
P M K N S H
✓ ✓



Locomotive Power Train Engine

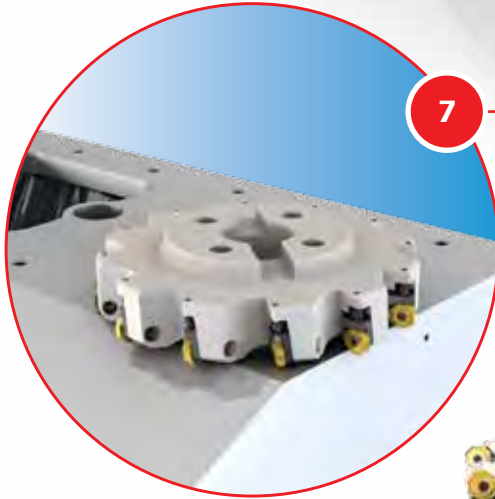

7

16MILL

Face Milling (Finish)

Special face milling cutters with adjustable cartridges carrying 16 cutting edged inserts for finishing operations.

SUMO TEC
810
P M K N S H
✓ ✓



*SPECIALLY
TAILORED*

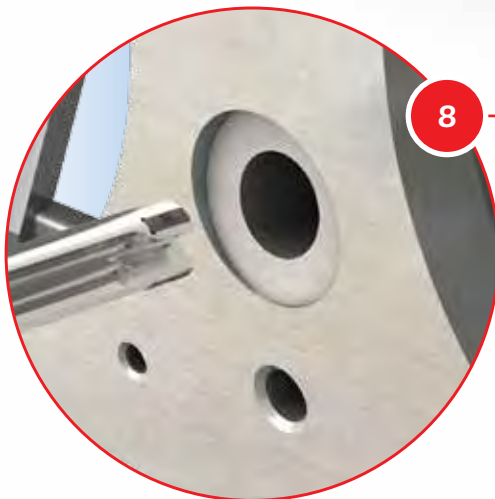
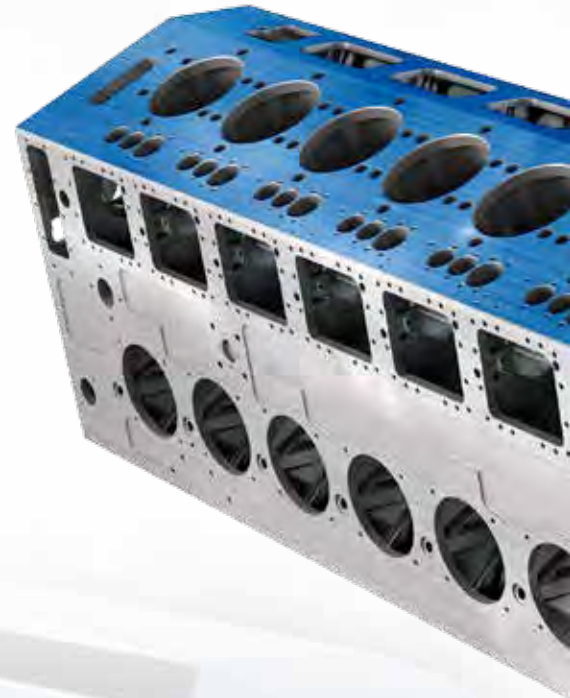
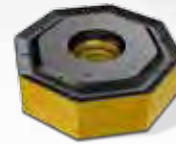

8

ISCARDR-DH

Deep Drilling

Range: Ø25 - 65 mm

Deep drills for milling centers and lathe machines with a drilling ratio of up to 7x D.

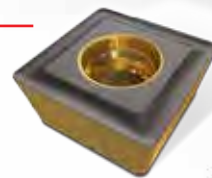



BAYOT-REAM

High Feed and Speed Reaming

Range: Ø11.5 - 32 mm

Interchangeable solid carbide reaming heads with a quick change bayonet mechanism; recommended for high productivity and accuracy.

908

P M K N S H
✓ ✓ ✓ ✓ ✓ ✓

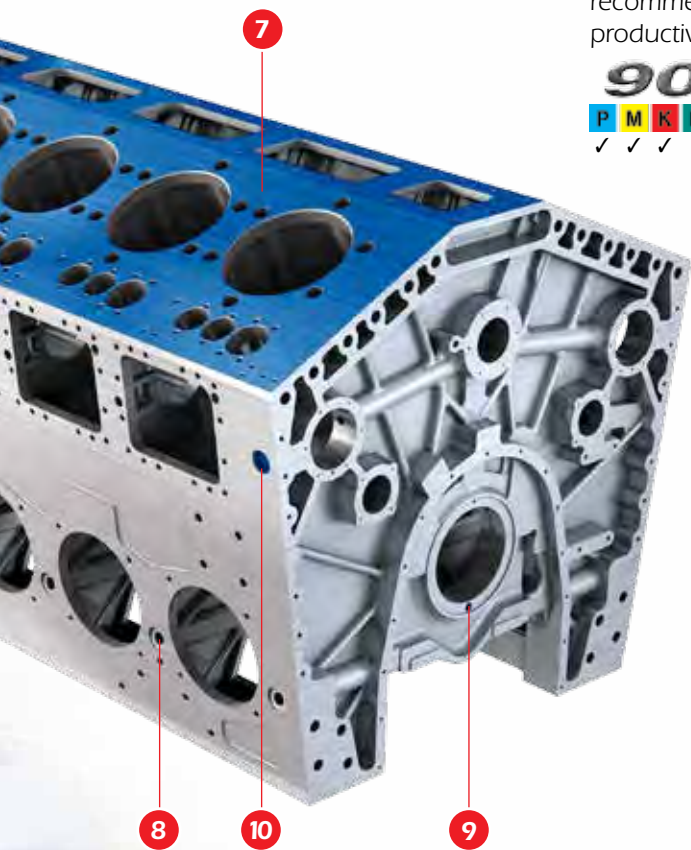

MILLTHREAD

Threading

Range: Ø12 - 40 mm

Internal thread milling and external precision thread milling on CNC machines by use of helical interpolation performed with NC programming. MILLTHREAD milling cutters, in addition to solid carbide cutters, are available with indexable thread milling inserts for any standard thread profile.

908

P M K N S H
✓ ✓ ✓ ✓ ✓ ✓



Wagons - Composite Materials

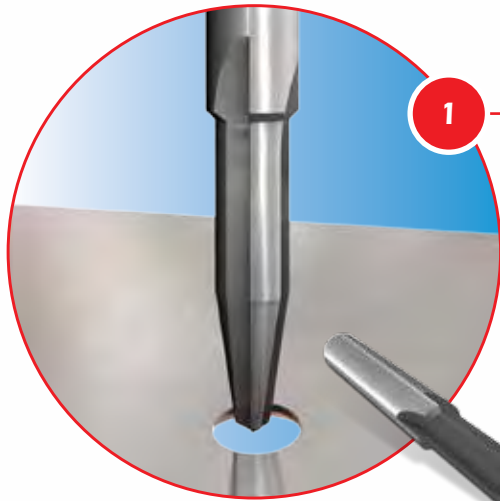

SOLIDDRILL

Drilling

Micrograin carbide endmills with a **diamond coating** for longer tool life and lower tangential forces which eliminate delamination.



ISCAR PCD LINE

Drilling and Countersinking

Spiral diamond tipped drills for countersinking and drilling in one step.

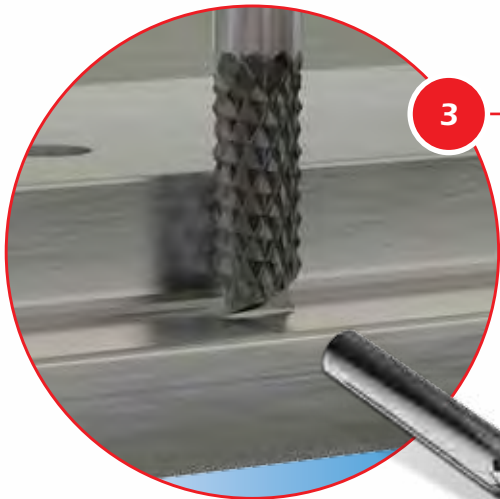

SOLIDMILL *SOLID CARBIDE LINE*

Milling

EPNC

Diamond coated drilling and milling tools with right and left spirals for rough trimming.





SOLIDMILL

SOLID CARBIDE LINE

Milling EPN-F

Diamond coated carbide endmill with right and left spiral flutes for side milling.

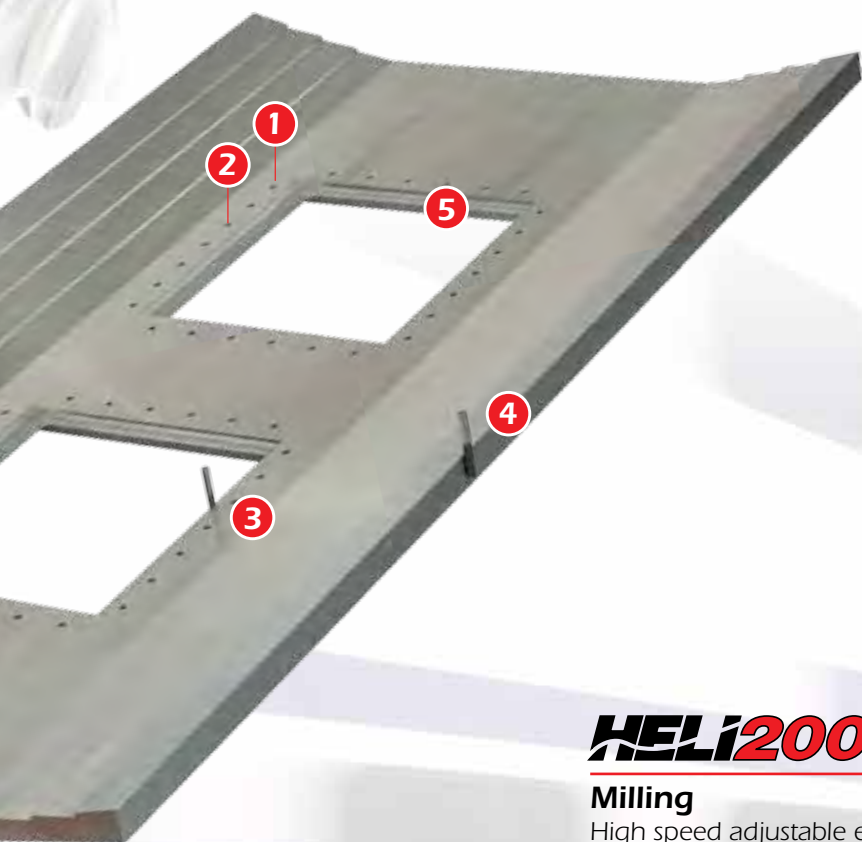

HELI2000

Milling

High speed adjustable endmills carrying ADKW 150508 PDR PCD tipped inserts, with excellent axial runout, for face milling.

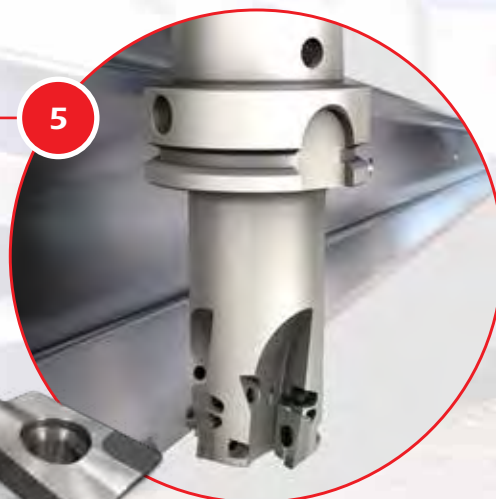

ISCAR PCD LINE



ISCAR's Solutions for the Railway Industry

